



AMC-1AREF Series

Refrigerant Gas Monitor

INSTRUCTIONS

Installation and Operation of the
AMC-1AREF Series Refrigerant Gas Monitor

IMPORTANT:

Please read these installation and operating instructions completely and carefully before starting

Filename: 3314405D.doc

Revised Jan 2018
Copyright © August, 2013, AMC

The Armstrong Monitoring Corporation
215 Colonnade Road South, Ottawa, Ontario, Canada K2E 7K3
Tel: (613) 225-9531 • Fax: (613) 225-6965 • Canada & U.S. Toll Free: 1-800-465-5777
E-mail: gas@armstrongmonitoring.com • Internet: www.armstrongmonitoring.com



TABLE OF CONTENTS

Section Title	Page
1 General Information.....	1
1.1 WARRANTY	1
1.2 LIABILITY	1
1.3 MODIFICATIONS AND SUBSTITUTIONS.....	1
1.4 PRODUCT RETURN.....	1
2 PRODUCT INFORMATION.....	2
3 PRODUCT DESCRIPTION	3
3.1 GENERAL DESCRIPTION	3
3.1.1 MONITOR FEATURES	3
4 INSTALLATION	6
4.1 MOUNTING INSTRUCTIONS	6
4.1.1 MONITOR MOUNTING	6
4.1.2 SENSOR/TRANSMITTER MOUNTING	7
4.2 WIRING	7
4.2.1 MONITOR WIRING	7
4.2.2 AMC-RAC WIRING	9
4.2.2.1 AMC-RAC to AMC-1AREF wiring	9
4.2.2.2 AMC-RAC to AMC-RAM-4 wiring.....	9
4.2.2.3 MULTIPLE AMC-RAM-4 WIRED TO A 1A MONITOR.....	11
4.2.2.4 JB1-4 Display Shunts.....	14
4.2.2.5 AMC-RAC to Emergency Pull Station (Optional)	15
4.2.3 TRANSMITTER CABLE SELECTION.....	16
4.2.3.1 Transmitter and Building Automation System	16
4.2.3.1.1 2-wire Transmitter Wiring.....	17
4.2.3.1.2 3-wire Transmitter Wiring.....	18
4.2.3.1.3 Building Automation Wiring.....	19
4.3 DIP SWITCH PROGRAMMING	22
4.3.1 DSI INTERFACE CONFIGURATION.....	24
4.4 ALARM RELAY PROGRAMMING	26
4.5 AUDIO ALARMS	26
5 OPERATION AND CALIBRATION.....	27
5.1 POWER-ON DELAY.....	27
5.2 TEST SWITCH FUNCTION.....	27
5.3 AUDIO ACKNOWLEDGE FUNCTION	27
5.4 ALARM/WARNING RELAY ACTIVATION DELAYS	27
5.5 RELAY OUTPUTS.....	28
5.6 GAS CONCENTRATION DISPLAY	28
5.7 CALIBRATION AND VERIFICATION.....	28
5.7.1 TRIP THRESHOLD ADJUSTMENT	29
5.7.1.1 Equipment Required	30
5.7.1.2 Trip Threshold Adjustment.....	30
5.7.2 2-WIRE AND 3-WIRE TRANSMITTERS.....	31
5.7.3 GAS CONCENTRATION DISPLAY SETUP	31
6 PREVENTIVE MAINTENANCE	33
6.1 GENERAL	33
6.2 VERIFICATION OF OPERATION	33
6.3 SENSOR REPLACEMENT	33



7 INSTALLATION TIPS AND TRICKS34

Figures and Tables

Figure 3-1 Gas Monitor 1AREF, Front Cover 5
Figure 3-2 Internal Features of the Gas Monitor 1AREF 5
Figure 4-1 Locations of Mounting Holes. 6
Figure 4-2 Location of Power Supply Connections. 8
Figure 4-3 Relay Contact Arrangement Relay 8
Figure 4-4 AMC-1AREF Monitor Connection to AMC-RAM-4 10
Table 4-1 AMC-1AREF Wiring to AMC-RAM-4 External with 2 displays 11
Table 4-2 AMC-1AREF Wiring to AMC-RAM-4 Internal with 2 displays 11
Table 4-3 Wiring Multiple Power and Signal Terminals in Parallel..... 12
Table 4-4 Wiring Multiple Displays for AMC-RAM-4 in Series 13
Table 4-5 Wiring Multiple AMC-RAM-4 with no Displays 14
Table 4-6 JB1-4 Display Shunt Placement 14
Figure 4-6 Wiring the AMC-1AREF to the Pull Station 15
Table 4-7 Wiring AMC-1AREF to Pull Station..... 15
Figure 4-7 Signal Input/Output Terminal Block. 16
Figure 4-8 AMC-1AREF Wiring to 2-Wire Transmitter. 17
Figure 4-9 AMC-1AREF Wiring to 3-Wire Transmitters 18
Figure 4-10 AMC-RAM-4 with Displays, BAS and AMC-RAC 19
Table 4-8 AMC-RAC to AMC-RAM-4 Internal with display and BAS Channel 1..... 19
Table 4-9 AMC-RAC to AMC-RAM-4 External with Displays and BAS Channel 2..... 19
Figure 4-11 Building Automation Wiring to AMC-1AREF..... 20
Table 4-10 AMC-RAC to BAS Channel 1 Connection. 20
Table 4-11 AMC-RAC to BAS Channel 2 Connection. 20
Figure 4-12 Graph showing distance (ft) vs. wire gauge (AWG) for various system setups. 21
Table 4-12 DIP-Switch Programming Chart..... 22
Figure 4-13 Detailed DSI Board..... 24
Table 4-13 Dip Switch setting for DSI board..... 24
Table 4-14 DSI board Test points (use a voltmeter with greater than 100K input resistance).... 25
Table 4-15 WARNING and ALARM Relay Active State..... 26
Table 4-16 Audio Alarm Operation 26
Table 5-1 Test Points and Trimpots Allocation 29
Figure 5-1 Gas Monitor 1AREF Test Points and Trimpots. 29
Table 5-2 Trip Threshold Adjustment..... 30
Table 5-3 Display DIP-Switch Settings 32
Figure 5-2 Back View of Gas Concentration Display 32



1 General Information

1.1 WARRANTY

The AMC-1AREF Series Monitor is warranted against defects in material and workmanship for a period of two (2) years from date of shipment. During the warranty period, The Armstrong Monitoring Corporation will repair or replace components that prove to be defective in the opinion of AMC. We are not liable for auxiliary interfaced equipment, or consequential damage. This warranty shall not apply to any product, which has been modified in any way, which has been repaired by any other party other than a qualified technician or authorized AMC representative, or when such failure is due to misuse or conditions of use.

1.2 LIABILITY

All AMC products must be installed and maintained according to instructions. Only qualified technicians should install and maintain the equipment. AMC shall have no liability arising from auxiliary interfaced equipment, for consequential damage, or the installation and operation of this equipment. AMC shall have no liability for labour or freight costs, or any other costs or charges in excess of the amount of the invoice for the products.

THIS WARRANTY IS IN LIEU OF ALL OTHER WARRANTIES, EXPRESSED OR IMPLIED, AND SPECIFICALLY THE WARRANTIES OF MERCHANTABILITY AND FITNESS FOR A PARTICULAR PURPOSE. THERE ARE NO WARRANTIES THAT EXTEND BEYOND THE DESCRIPTION ON THE FACE THEREOF.

1.3 MODIFICATIONS AND SUBSTITUTIONS

Due to an ongoing development program, AMC reserves the right to substitute components and change specifications at any time without incurring any obligations.

1.4 PRODUCT RETURN

All products returned for warranty service will be by prepaid freight and they will only be accepted with an R.M.A. number issued by AMC. All products returned to the client will be freight collect.

Service Department contact information:
Web: www.armstrongmonitoring.com
North America toll free: 1 (800) 465-5777



2 PRODUCT INFORMATION

Monitor Part Number. AMC-1AREF

Monitor Serial Number. _____

Monitor Warranty Period. 2 years

DSI Part Number. _____

DSI Serial Number. _____

DSI Warranty Period. 2 years

Power Supply Requirement. 120 VAC, 60 Hz, 54 VA

Operating Temperature..... 0°C to +40°C (32°F to +104°F)

Operating Pressure..... Ambient atmospheric pressure

Relative Humidity..... 0 – 90% non-condensing.

Signal Input Configuration	Part No.	Serial No.	Type of Gas	Alarm Trip Points		Full Scale
				Warning	Alarm	
Transmitter Ch1						
Transmitter Ch2						

TORQUE SPECIFICATIONS:

POWER SUPPLY:

Neutral terminal screw 7 pound-inches.

Hot terminal screw 7 pound-inches.

Ground Lug screw. 15 pound-inches.

RELAY:

Relay socket terminal screws 7 pound-inches.

Note:

All Armstrong Monitoring systems must be installed and maintained according to instructions, to ensure proper operation. Only qualified technicians should install and maintain the equipment.



3 PRODUCT DESCRIPTION

3.1 GENERAL DESCRIPTION

The AMC-1AREF series gas monitoring system includes the AMC-DSI sensor interface board and a Remote Alarm Controller, which has connectivity for the AMC-RAM-4 Refrigerant Alarm Modules. The DSI board permits up to two 4-20 mA sensor/transmitters to be connected. The monitor comes with the following features, see Figure 3-1 Gas Monitor 1AREF, Front Cover and Figure 3-2 Internal Features of the Gas Monitor 1AREF

3.1.1 MONITOR FEATURES

1. RUN/FAULT/OFF INDICATOR: A green LED for each channel.
RUN: LED on
FAULT: LED flashing
OFF: LED off
2. WARNING INDICATOR: Warning levels of gas are indicated by a yellow LED for each channel. Warning concentrations are indicated in Section 2
3. ALARM INDICATOR: Alarm levels of gas are indicated by a red LED for each channel. Alarm concentrations are indicated in Section 2
4. GAS CONCENTRATION DISPLAYS(OPTIONAL): A visual indication of the gas concentration for channel 1 and 2
5. POWER TERMINAL BLOCK: For line voltage connections of 120 VAC, 60 Hz
6. TRANSFORMER: A step down transformer powers the internal circuitry and remote sensor at low voltages. Located underneath the PCB
7. INTERNAL WIRING HEADER: Provides wiring connection points to relays, buzzer and the AMC-RAC
8. AUDIO ALARM INDICATOR: The buzzer will activate for Alarm, Warning (configurable) and Fault conditions, with a distinct tone for each one
9. RELAY SETUP JUMPERS Used to independently configure the Warning/Ch1 and Alarm/Ch2 relays as Normally Energized or Non-Energized
10. TEST SWITCH: The test switch is provided to electronically simulate alarms in order to test audio and relay functions
11. CHANNEL 1 ADJUSTMENT: Signal, Alarm and Warning for channel 1



12. CHANNEL 2 ADJUSTMENT: Signal, Alarm and Warning for channel 2
13. PROGRAMMING DIP SWITCHES: Allows user to configure the alarm delay and timer circuits, audio alarm activation, sensor mode selection, fault threshold, and acknowledge switch function
Switches are located under the DSI board. Do not unplug DSI board under power.
14. RELAYS: 3 DPDT Relays, 1 for Alarm state, 1 for Warning state and 1 dedicated to ventilation.
15. DSI BOARD : DSI board allows 4-20mA signal input and a 4-20mA signal output. The AMC-RAC is connected to the AMC-1AREF through the DSI board

16. SIGNAL INPUT TERMINAL BLOCK: DSI
J5 and J6

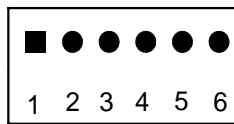

Allows connection to transmitter input and output
Channel 1: Pins 1-6 ----J5
Channel 2: Pins 1-6 ----J6
1 - Signal ground (DO NOT USE)
2 - 4-20mA out (DO NOT USE)
3 - Power
4 - 4-20mA in
5 - Chassis ground
6 - Signal ground

17. AMC-RAC The Remote Alarm Controller, factory installed for communication between the AMC-DSI and RAM-4s. The RAC includes 3 LEDs; Green –power, Yellow -ventilation on, and Red- shutdown



AMC-1AREF Series Refrigerant Monitor

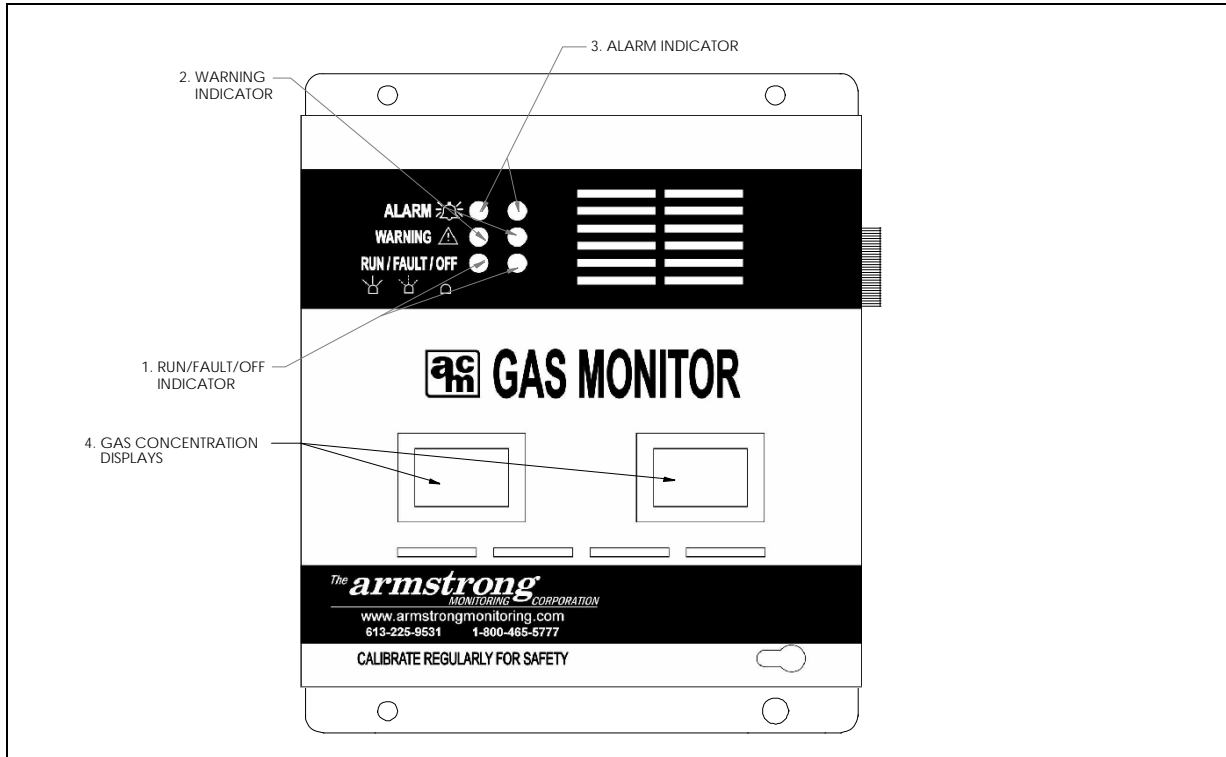

Figure 3-1 Gas Monitor 1AREF, Front Cover

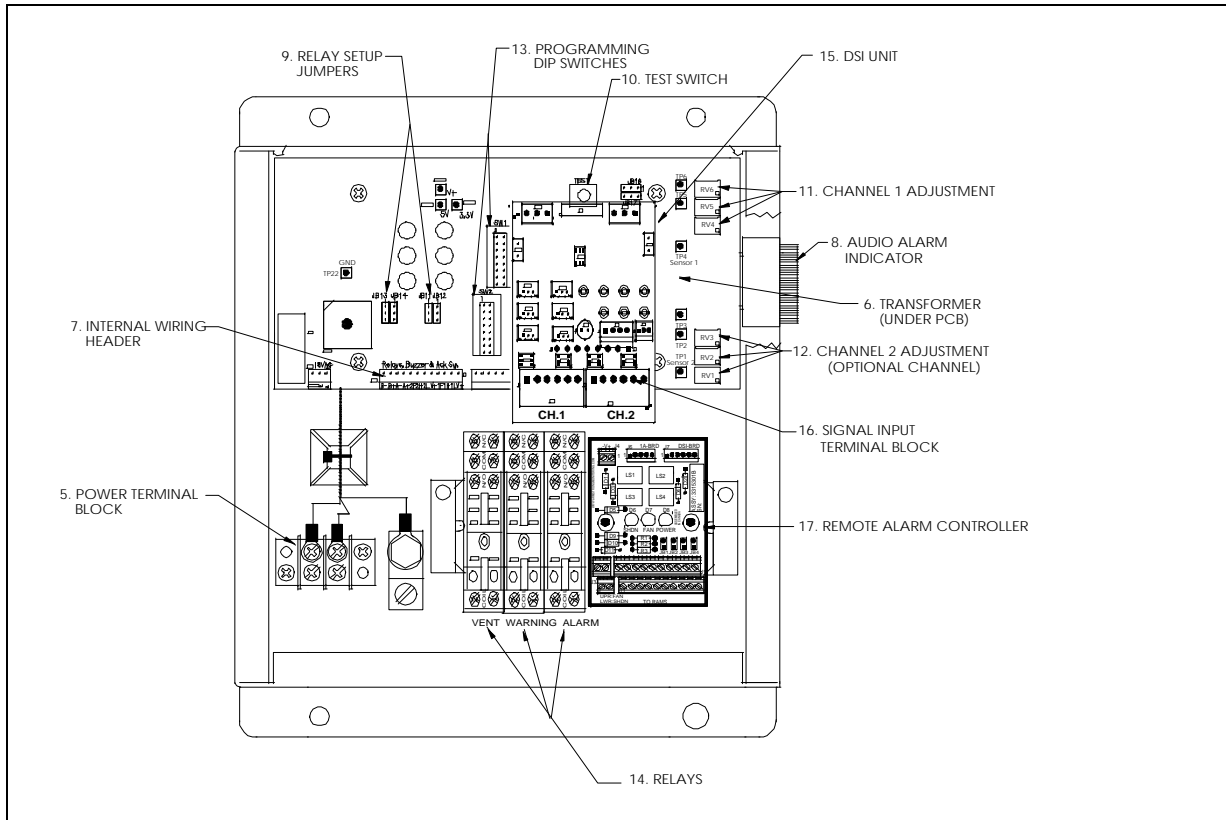

Figure 3-2 Internal Features of the Gas Monitor 1AREF



4 INSTALLATION

Follow the guidelines in this section for proper locations and installation of the AMC-1AREF series monitor. In addition to these instructions, ensure installation is compliant with local building, mechanical and electrical codes. This section covers topics related to installation location, mounting, cable selection, wiring instructions and monitor function programming for the AMC-1AREF series monitor.

4.1 MOUNTING INSTRUCTIONS

4.1.1 MONITOR MOUNTING

Securely fasten the AMC-1AREF series monitor unit on a solid, non-vibrating surface or structure. Install the unit where it will not be exposed to rain or water spray. Mount the monitor where the unit can be observed periodically. For most applications the monitor should be mounted at eye level, see Figure 4-1 Locations of Mounting Holes.

CAUTION: All cable entry MUST BE through the BOTTOM of the monitor enclosure only. Other entry locations will allow foreign materials to enter the enclosure, causing possible non-warranty damage to the internal components.

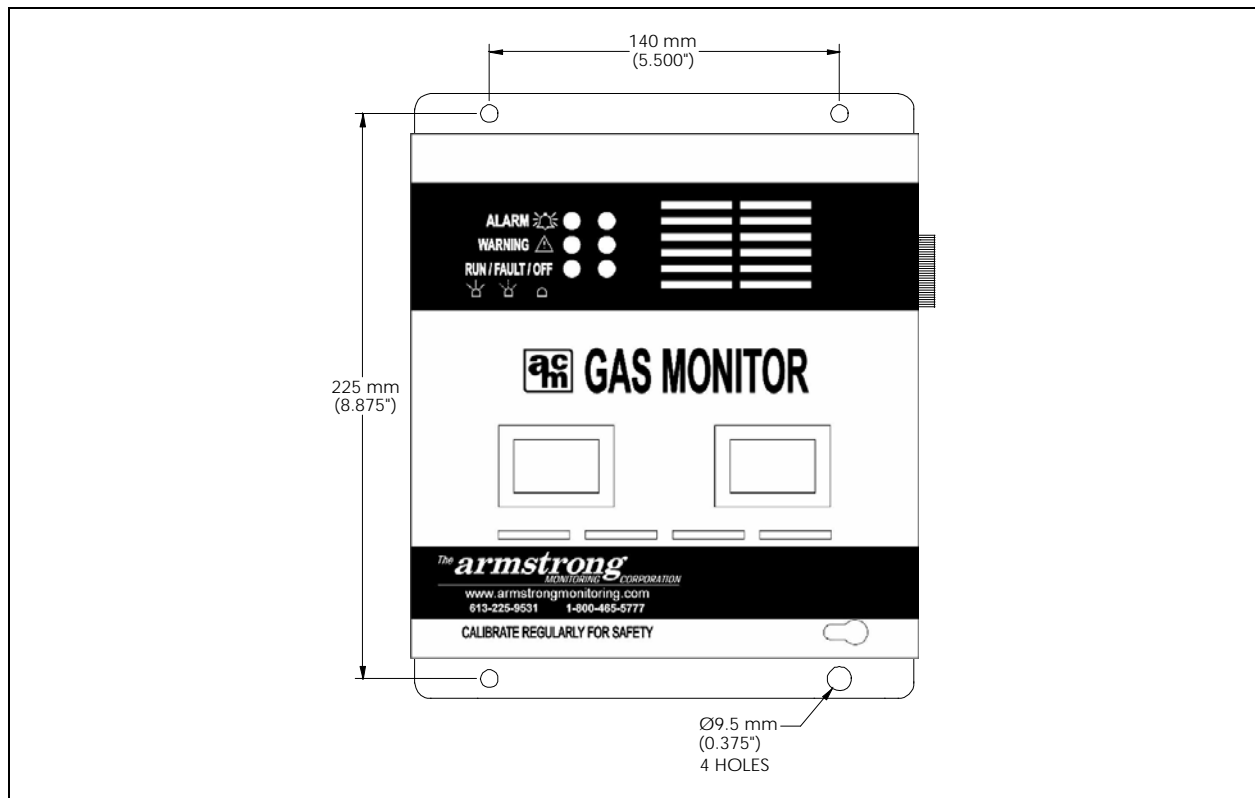

Figure 4-1 Locations of Mounting Holes.



4.1.2 SENSOR/TRANSMITTER MOUNTING

The refrigerant gas detector shall be located on a solid, non-vibrating surface or structure in an area where refrigerant from a leak is most likely to concentrate, and away from the prevalent airflows in the space. The alarms in the AMC-1AREF series gas monitor shall be actuated at a value not greater than the corresponding Threshold Limit Value / Time Weighted Average (TLV/TWA) (or a consistent toxicity measure) of the gas being monitored.

Mounting heights and location vary depending on application and target refrigerant gas properties. Considering airflow is important for good placement as sensor/Transmitter should normally be located on the side closest to the room air exhaust rather than the side closest to the room air intake. Consult MSDS sheets for gas density in relation to air to determine mounting height or contact Armstrong Monitoring Corporation if further assistance is required.

4.2 WIRING

4.2.1 MONITOR WIRING

POWER SUPPLY: The monitor operates on 120 VAC, 60 Hz. A step down transformer runs the internal circuitry at low voltages. The power supply connections are made at the power terminal block located inside the monitor, see Figure 4-2.

3 RELAYS: 3 DPDT relays are used. Two of the relays are set for different alarm conditions, customizable for required operations and the third relay is used for activation of the ventilation system. The contacts are rated for 8 Amps @ 250VAC resistive. For relay contact arrangement, see Figure 4-3. Please note that relays are Non-Energized unless specified.

Jumper settings are factory configured based on the specifics of the configuration requested. See section 4.4 for jumper configuration. Certain options can be set according to user preferences in the field.



AMC-1AREF Series Refrigerant Monitor

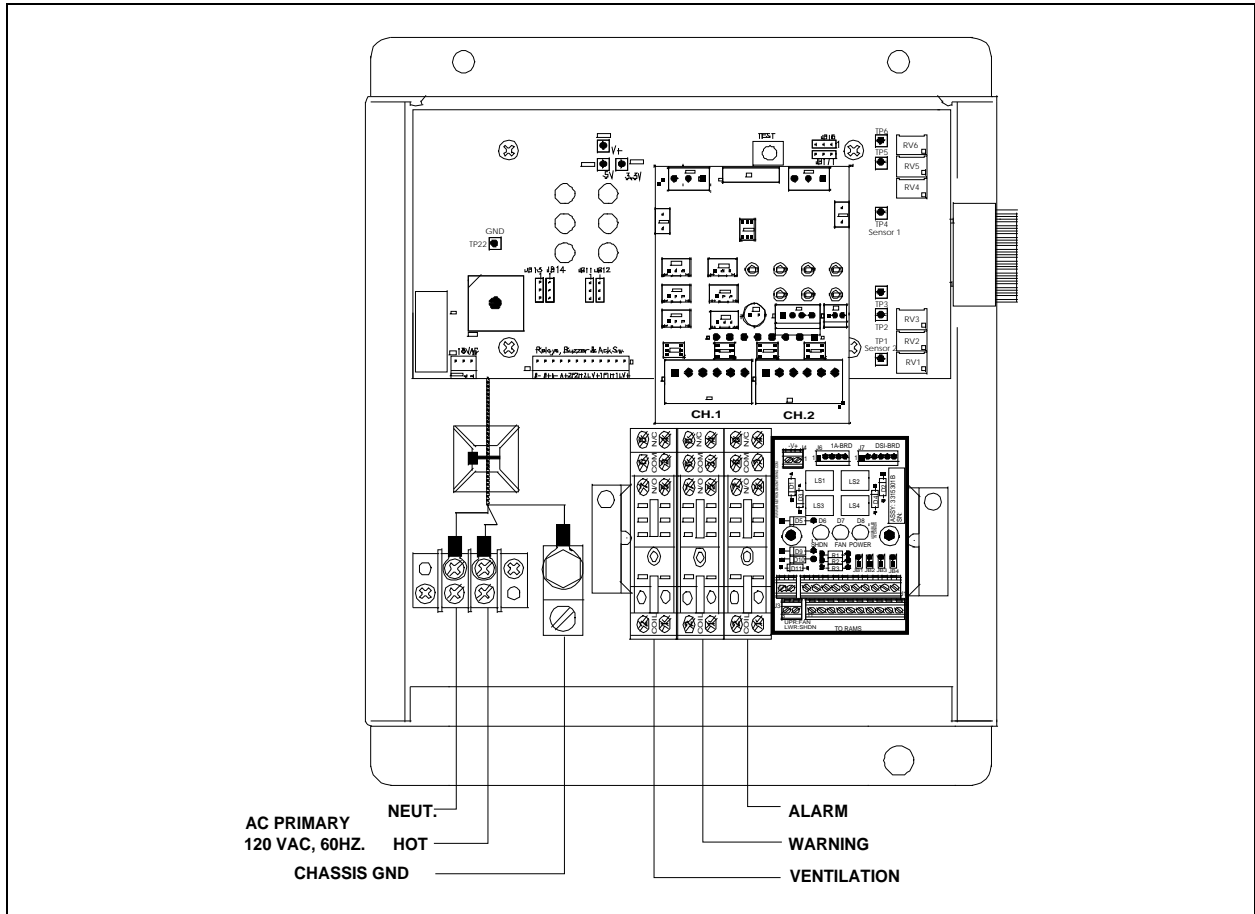

Figure 4-2 Location of Power Supply Connections.

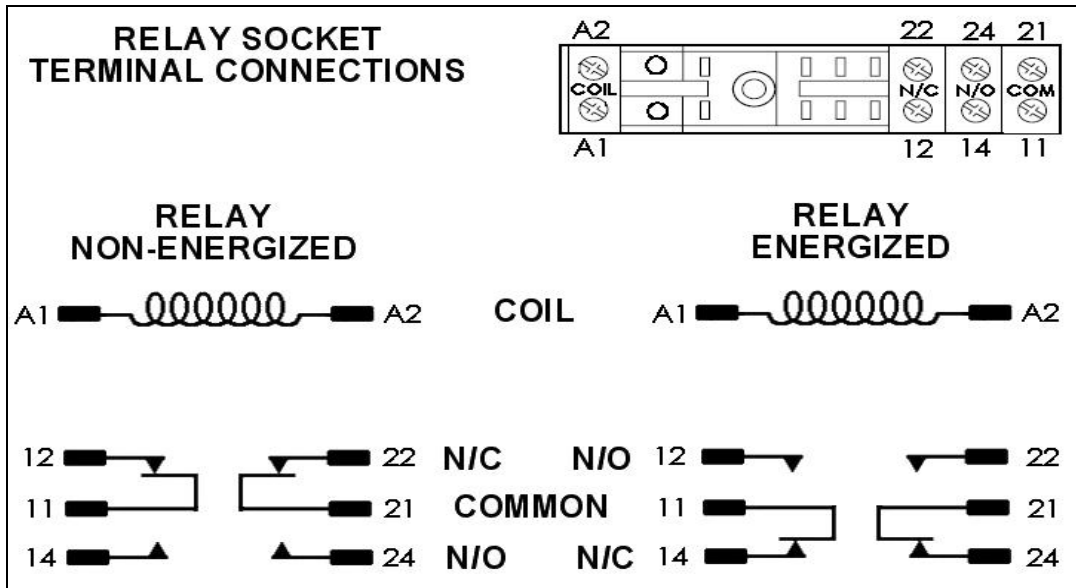

Figure 4-3 Relay Contact Arrangement Relay



4.2.2 AMC-RAC WIRING

The Remote Alarm Controller provides communication between the AMC-1AREF monitor, DSI board, and AMC-RAM-4 Refrigerant Alarm Modules. Its functions include controlling the ventilation relay manually by remote fan switches on the AMC-RAM-4 or automatically if a refrigerant leak is detected.

4.2.2.1 AMC-RAC to AMC-1AREF wiring

The AMC-RAC is factory wired to the AMC-1AREF monitor through the DSI board; the signal from the DSI board is relayed to the AMC-RAC which then sends the signal out to the attached peripherals. The communication from the AMC-RAM-4 is also relayed through the AMC-RAC to activate the ventilation relay.

4.2.2.2 AMC-RAC to AMC-RAM-4 wiring

The AMC-RAM-4 units are connected to the AMC-1AREF monitor through the AMC-RAC as shown in Figure 4-4. Please utilize Tables and Figure drawings to complete wiring. JB1-4 Shunts on the AMC-RAC must be installed correctly for display operation.

IMPORTANT NOTE:

Internal RAM-4 Units are installed inside Chiller rooms while **External** RAM-4 Units are installed outside Chiller rooms. **External** units do not have a stop button (no connection at pos. 4 on terminal block J1 or J2 in the AMC-RAC), while the **Internal** units have a stop button.

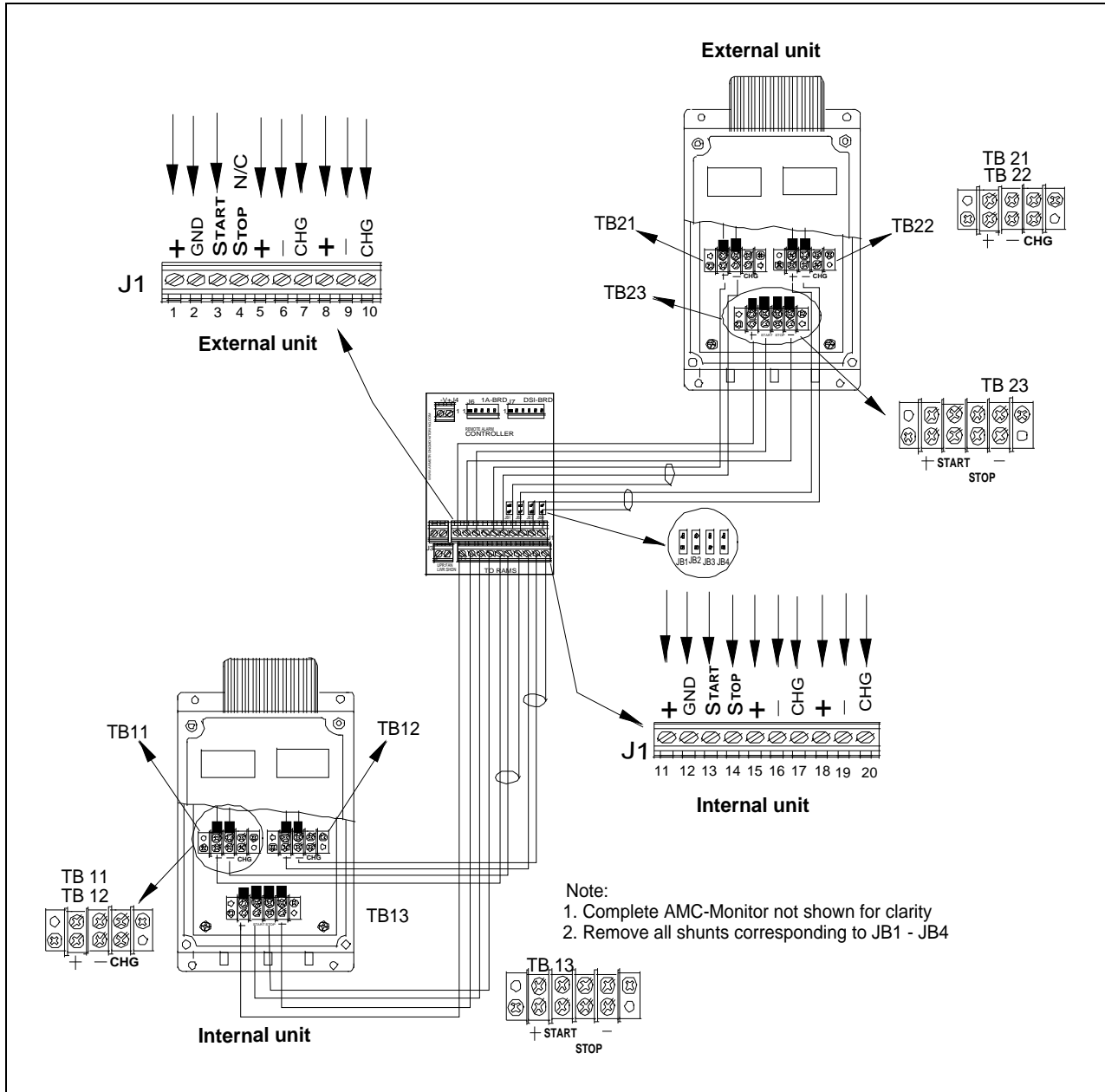

Figure 4-4 AMC-1AREF Monitor Connection to AMC-RAM-4

Note: The + and – signals on J1 pins 5,6,8,9,15,16,18,19 carry 4-20 loop current while pin 1 + is required for Ram-4 power. Ensure tables and figure drawings are followed when wiring units due to differences in signal functions.



Table 4-1 AMC-1AREF Wiring to AMC-RAM-4 External with 2 displays

RAM-4	Function	AMC-1AREF Monitor (RAC)
TB23		J1 Terminal Block position
(+)	RAM-4 Alarm	1
START	Activate Vent Relay	3
STOP	Deactivate Vent Relay	N/C
(-)	Ground	2
TB21		J1 Terminal Block position
(+)	CH1. Current Loop Positive 1	5
(-)	CH1. Current Loop Negative 1	6
CHG	Current Loop Chassis Ground	7
TB22		J1 Terminal Block position
(+)	CH2. Current Loop Positive 1	8
(-)	CH2. Current Loop Negative 1	9
CHG	Current Loop Chassis Ground	10

Table 4-2 AMC-1AREF Wiring to AMC-RAM-4 Internal with 2 displays

RAM-4	Function	AMC-1AREF Monitor (RAC)
TB13		J1 Terminal Block position
(+)	RAM-4 Alarm	11
START	Activate Vent Relay	13
STOP	Deactivate Vent Relay	14
(-)	Ground	12
TB11		J1 Terminal Block position
(+)	CH1. Current Loop Positive 1	15
(-)	CH1. Current Loop Negative 1	16
CHG	Current Loop Chassis Ground	17
TB12		J1 Terminal Block position
(+)	CH2. Current Loop Positive 1	18
(-)	CH2. Current Loop Negative 1	19
CHG	Current Loop Chassis Ground	20

4.2.2.3 MULTIPLE AMC-RAM-4 WIRED TO A 1A MONITOR

When more than two AMC-RAM-4 modules are required, the modules can be connected in parallel BUT the optional displays have to be connected in series. Figure 4-5

Caution: Ensure that the power supply at the monitor is large enough to power all devices or use the configuration that has no more than 2 displays per channel.

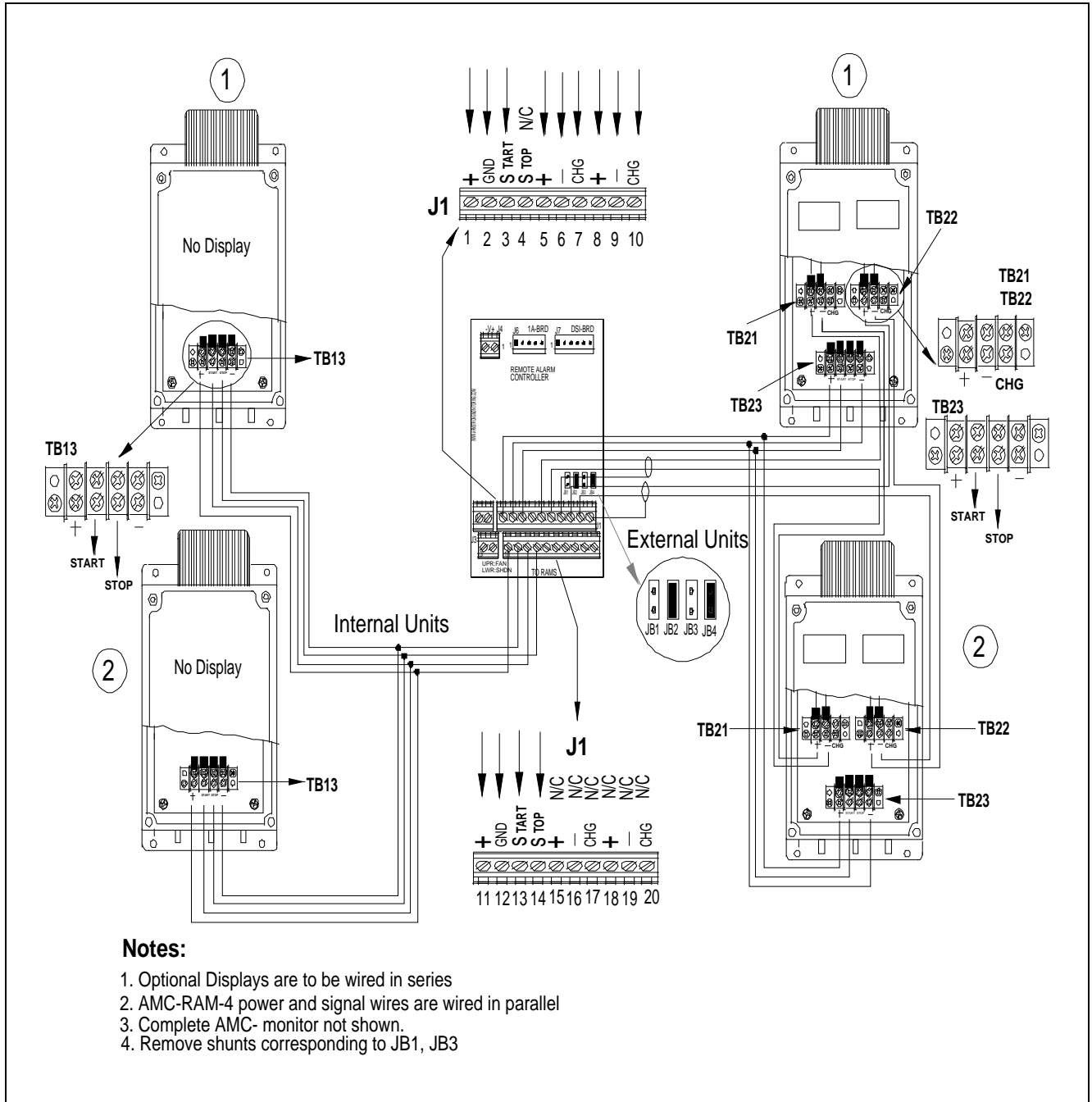

Figure 4-5 Multiple RAM-4 to 1A Monitor Diagram

Table 4-3 Wiring Multiple Power and Signal Terminals in Parallel

AMC-RAM-4	Function	AMC-1AREF Monitor/ RAM-4
TB23 Unit 1		J1 Terminal block
(+)	Ram-4 Alarm	1
START	Activate Vent Relay	3



AMC-1AREF Series Refrigerant Monitor

STOP	Deactivate Vent Relay	N/C
(-)	Ground	2
TB23 Unit 2		TB23 Unit 1
(+)	Ram-4 Alarm	+
START	Activate Vent Relay	START
STOP	Deactivate Vent Relay	N/C
(-)	Ground	(-)

Table 4-4 Wiring Multiple Displays for AMC-RAM-4 in Series

AMC-RAM-4	Function	AMC-1AREF Monitor/ RAM-4
TB21 Unit 1		J1 Terminal block and TB21 unit 2
(+)	CH1. Current Loop Positive 1	J1 Terminal block pos. 5
(-)	CH1. Current Loop to next Ram-4	(+) TB21 unit2
CHG	Current Loop Chassis Ground	J1 Terminal block pos. 7
TB21 Unit 2		J1 Terminal block and TB21 unit 1
(-)	CH1. Current Loop return from last RAM-4	J1 Terminal block pos. 6
CHG	Current Loop Chassis Ground	J1 Terminal block pos. 7
TB22 Unit 1		J1 Terminal block and TB22 unit 2
(+)	CH2. Current Loop Positive 1	J1 Terminal block pos. 8
(-)	CH2. Current Loop to next Ram-4	(+) TB22 unit 2
CHG	Current Loop Chassis Ground	J1 Terminal block pos. 10
TB22 Unit 2		J1 Terminal block and TB22 unit 1
(-)	CH2. Current Loop return from last RAM-4	J1 Terminal block pos. 9
CHG	Current Loop Chassis ground	J1 Terminal block pos. 10



Table 4-5 Wiring Multiple AMC-RAM-4 with no Displays

AMC-RAM-4	Function	AMC-1AREF Monitor / RAM-4
TB13 Unit 1		J1 Terminal block
(+)	Ram-4 Alarm	11
START	Activate Vent Relay	13
STOP	Deactivate Vent Relay	14
(-)	Ground	12
TB13 Unit 1		TB13 Unit 2 (RAM-4)
(+)	Ram-4 Alarm	(+)
START	Activate Vent Relay	START
STOP	Deactivate Vent Relay	STOP
(-)	Ground	(-)

NOTES:

- Limit the number of displays for external devices wired up to the 1AREF monitor to 2 per channel due the current requirements of the displays and power supply.
- The Audio Silence will only silence the local AMC-RAM-4, not all AMC-RAM-4s connected to the circuit.
- When additional AMC-RAM-4s are required, an additional power supply may be required at the AMC-RAC.
- Shielded twisted pair wire is recommended for display wiring.

4.2.2.4 JB1-4 Display Shunts

The RAC J1 Pins 1-10 always connect to external units while the RAC J1 Pins 11-20 always connect to internal units. The shunts must be installed correctly to ensure the display current loops exist for different configurations.

The balance of Ram-4 functions do not depend on these shunts.

Table 4-6 JB1-4 Display Shunt Placement

JB1-4 install	Ram-4 Configuration
No shunts installed	1 External 2 Display and 1 Internal 2 Display (both Ch1/2 used)
No shunts installed	1 External 1 Display and 1 Internal 1 Display (only CH1 used)
JB2, JB4 installed	2 External 2 Display and 2 Internal No Display (both Ch1/2 used)
JB2 installed	2 External 1 Display and 2 Internal No Display (only CH1 used)
JB1, JB3 installed	2 Internal 2 Display and 2 External No Display (both Ch1/2 used)
JB1 installed	2 Internal 1 Display and 2 External No Display (only CH1 used)

4.2.2.5 AMC-RAC to Emergency Pull Station (Optional)

The Emergency Pull Station (AMC-EPS) is located immediately outside the mechanical room door and is intended to shut down any interlocked equipment in case of an emergency. The Pull Station is wired to the system through the AMC-RAC as shown in Figure 4-6. Once the Pull Station lever is pulled, it activates the alarm relay until the switch is reset.

Recommended wire size is 18-22 AWG and distance between AMC-RAC and pull station should not be more than 500 feet.

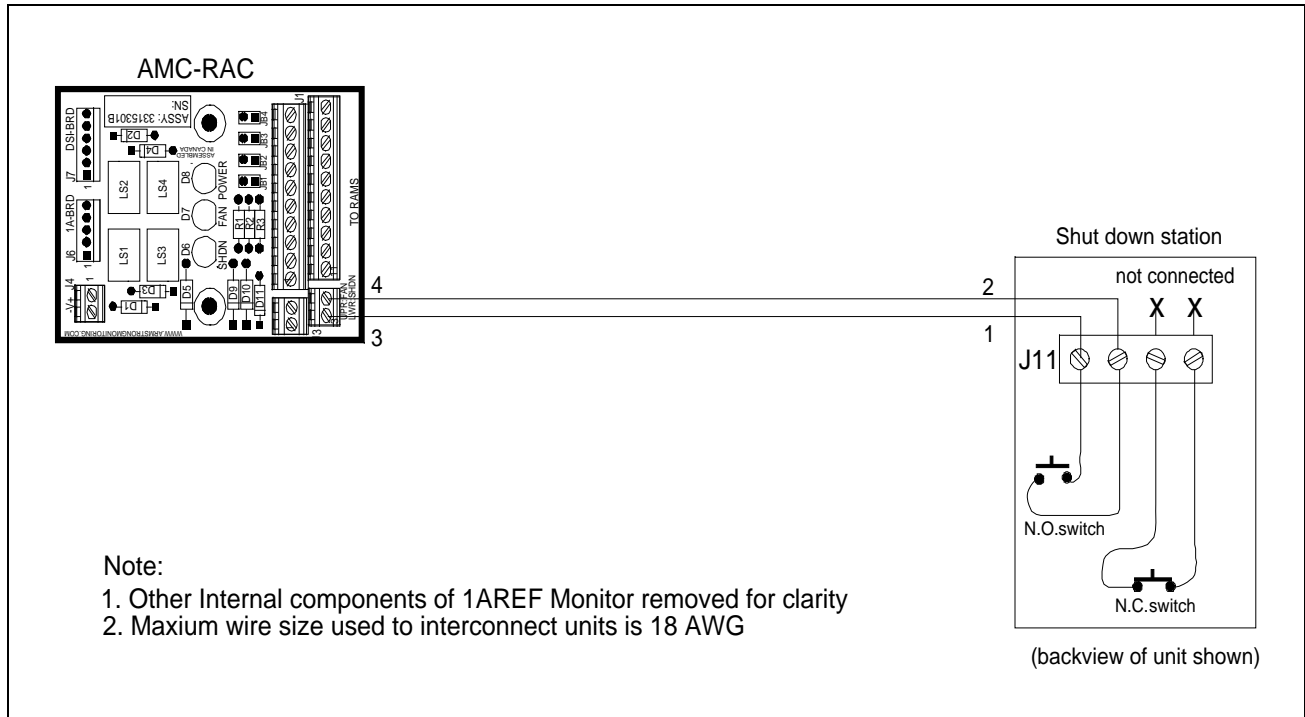

Figure 4-6 Wiring the AMC-1AREF to the Pull Station

Table 4-7 Wiring AMC-1AREF to Pull Station

1AREF Monitor J3	Function	Shut down Station J11
3	Positive	1
4	GND	2

4.2.3 TRANSMITTER CABLE SELECTION

Connections from monitor to sensor/transmitter should be made using shielded, 2 or 3-conductor cable (depending on type of sensor/transmitter used). For best signal transmission and maximum noise rejection, run cable through steel conduit (cable shield must be grounded at the monitor). For basic selection of cable size and length (between monitor and sensor/transmitter), refer to the cable selection chart in the appropriate transmitter manual. The monitor's field power supply is 18-22 VDC. The configuration for each signal input is shown in Figure 4-7.

4.2.3.1 Transmitter and Building Automation System

On the DSI board, the signal input/output terminal block (see Figure 3-2, item 16) allows two channel wiring for a remote 4-20mA sensor/transmitter input on each channel. Also, each channel has a 4-20mA signal follower output that is connected to the AMC-RAC. Figure 4-7 shows a detailed depiction of the signal input/output terminal block. The following sections detail the 2 wire, 3 wire transmitter, and building automation wiring.

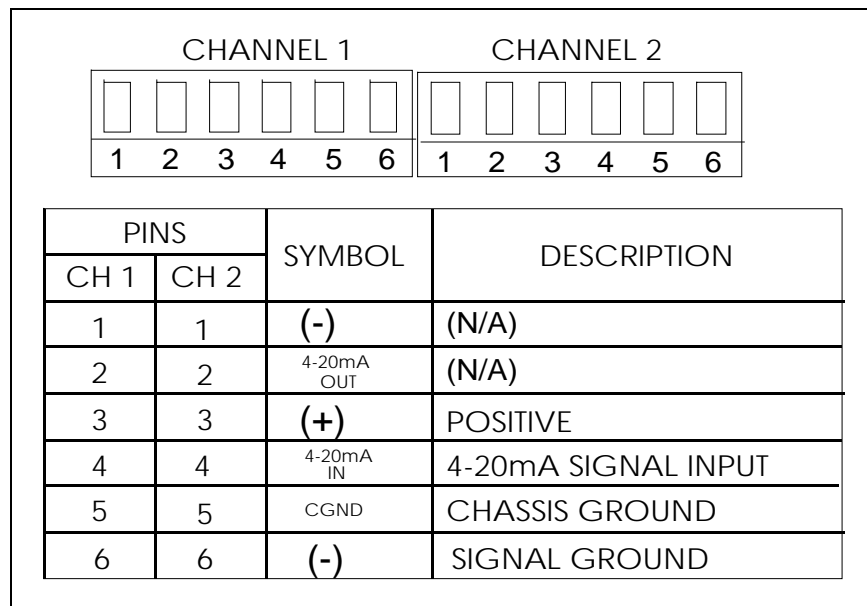

Figure 4-7 Signal Input/Output Terminal Block.

See specific transmitter manual for wire gauge recommendations, based upon installation distance from the monitor. Be certain to observe appropriate wire connection to specified monitor signal input channel to retain correct operation or factory set alarm functions.



4.2.3.1.1 2-wire Transmitter Wiring

The 2-wire transmitter is wired to the Gas Monitor through the signal input/ output terminal block on the DSI board as shown in Figure 4-8.

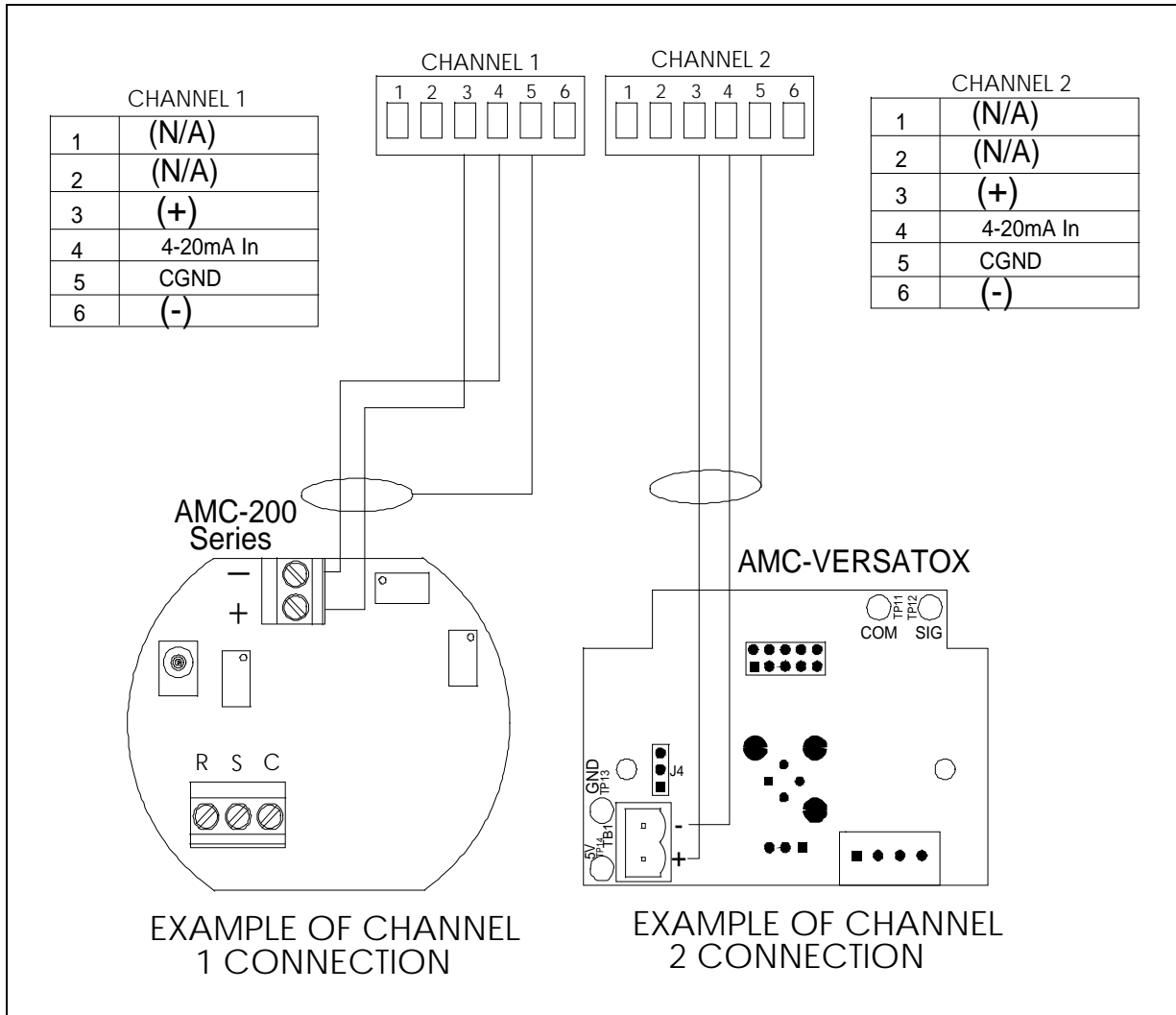

Figure 4-8 AMC-1AREF Wiring to 2-Wire Transmitter.



AMC-1AREF Series Refrigerant Monitor

4.2.3.1.2 3-wire Transmitter Wiring

The 3 wire transmitter is wired to the Gas Monitor through the signal input/output terminal block on the DSI board. The wiring for channel 1 and 2 are conveyed in the following Figure 4-9.

Figure 4-9 AMC-1AREF Wiring to 3-Wire Transmitters

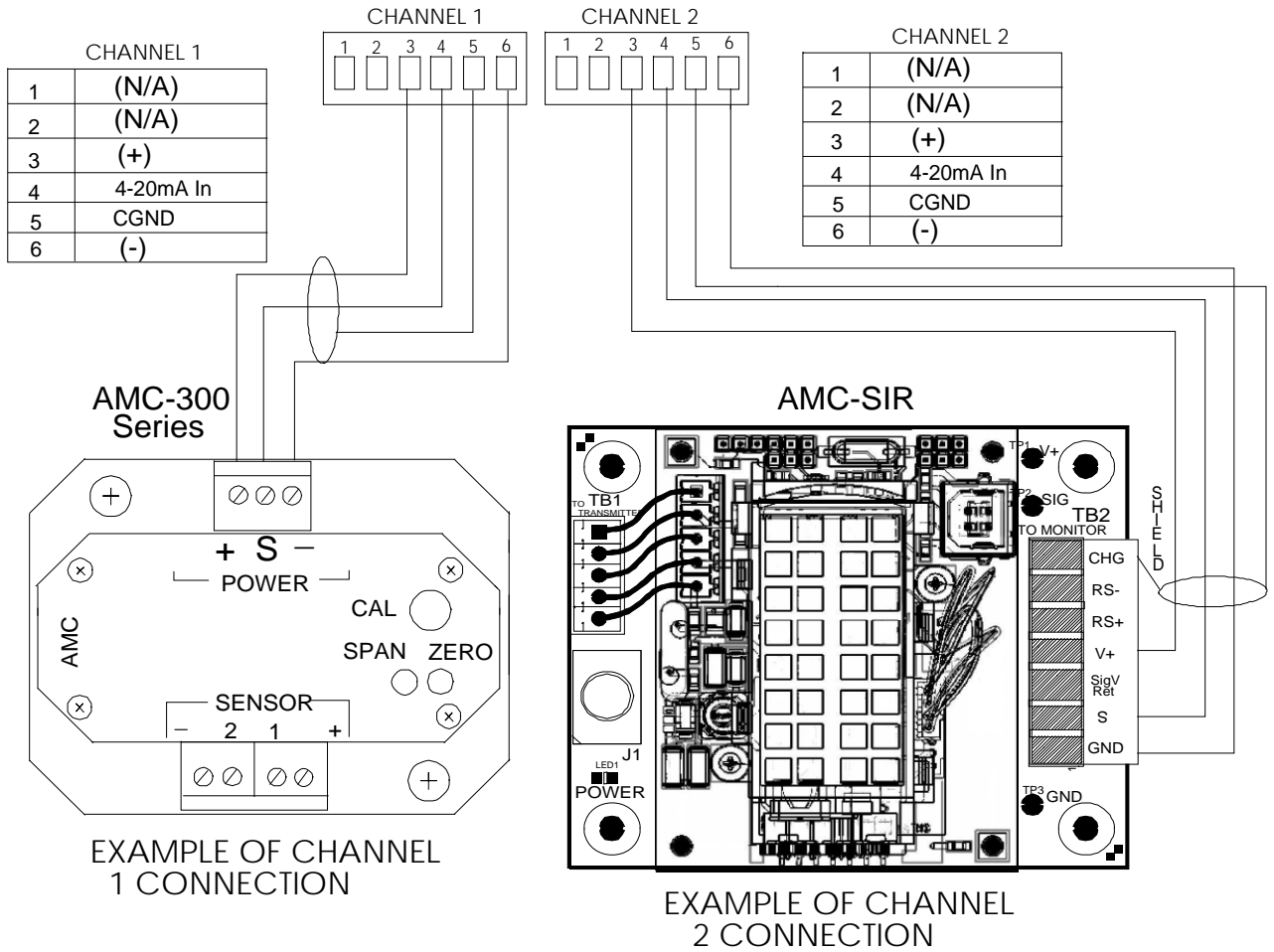



AMC-1AREF Series Refrigerant Monitor

4.2.3.1.3 Building Automation Wiring.

The building automation system (BAS) can be wired to the Gas Monitor through the AMC-RAC. The BAS can also be wired in series with AMC-RAM-4 module with displays through the AMC-RAC. Both wiring setups are conveyed in the Figures 4-10 and 4-11.

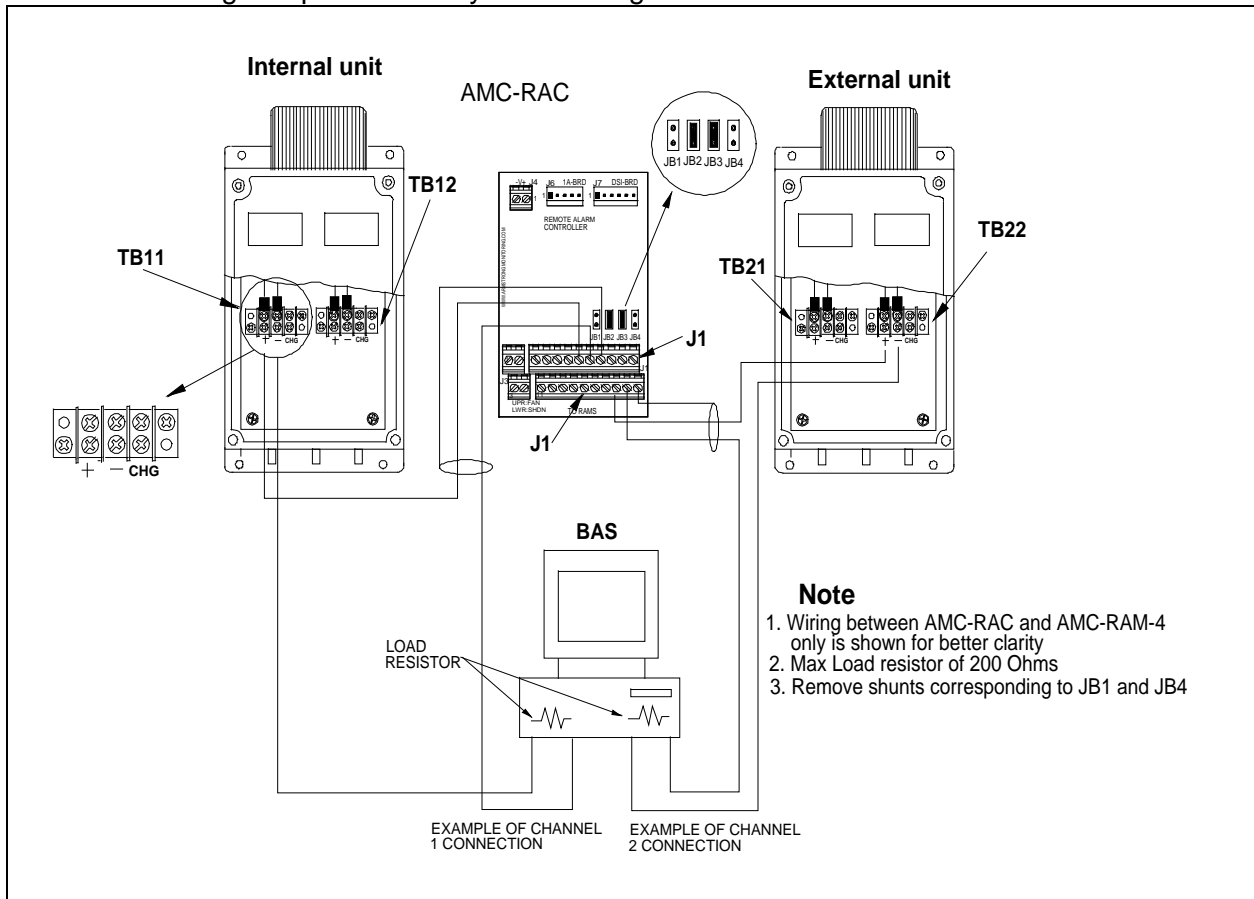

Figure 4-10 AMC-RAM-4 with Displays, BAS and AMC-RAC

Table 4-8 AMC-RAC to AMC-RAM-4 Internal with display and BAS Channel 1.

AMC-RAC	Function	AMC-RAM-4	BAS CH.1
J1 Terminal Block pos.5 (+)	CH1. Current Loop Positive 1	TB 11(internal) +	
N/A		TB 11(Internal) -	(+)
J1 Terminal Block pos.6 (-)	CH1. Current Loop Negative 1	N/A	(-)
J1 Terminal Block pos.7 (CHG)	Current Loop Chassis Ground		

Table 4-9 AMC-RAC to AMC-RAM-4 External with Displays and BAS Channel 2

AMC-RAC	Function	AMC-RAM-4	BAS CH.2
J1 Terminal Block pos.18 (+)	CH2. Current Loop Positive 1	TB 22(external) +	
N/A		TB 22(external) -	(+)
J1 Terminal Block pos.19 (-)	CH2. Current Loop Negative 1	N/A	(-)
J1 Terminal Block pos.20 (CHG)	Current Loop Chassis Ground		

NOTE

CABLE SHIELD MUST BE GROUNDED AT ONE END ONLY, EITHER AT GAS MONITOR OR BAS, BUT NOT BOTH.

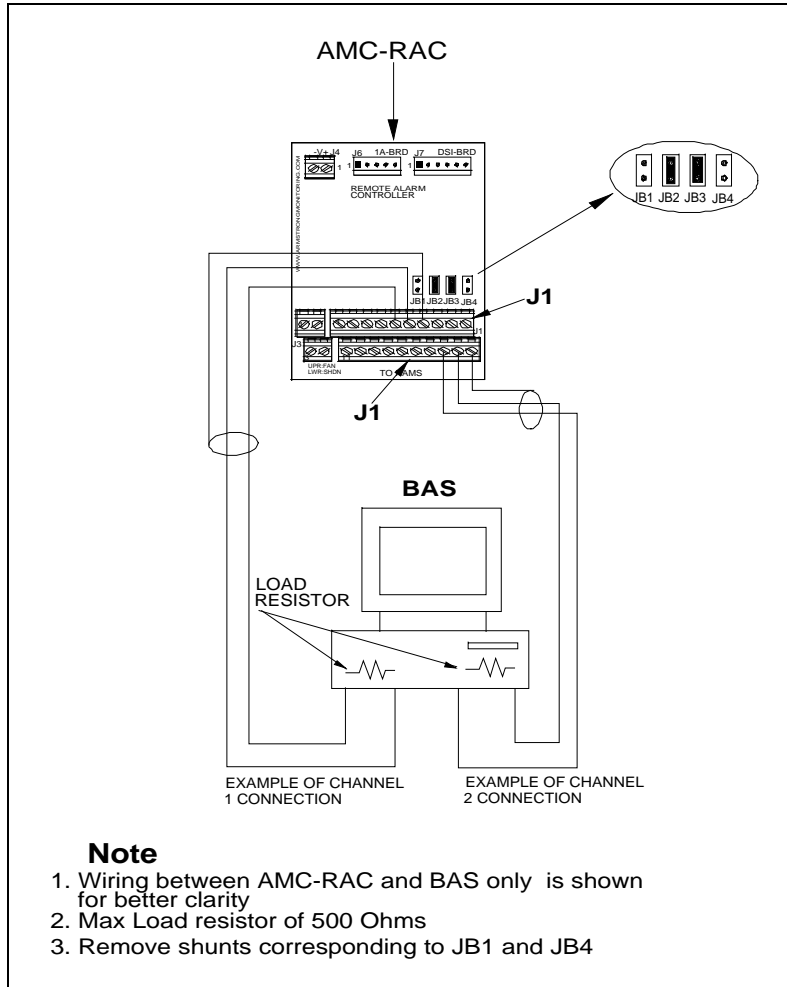

Figure 4-11 Building Automation Wiring to AMC-1AREF.

Table 4-10 AMC-RAC to BAS Channel 1 Connection.

AMC-RAC	Function	BAS CH.1
J1 Terminal Block pos.5 (+)	CH1. Current Loop Positive 1	(+)
J1 Terminal Block pos.6 (-)	CH1. Current Loop Negative 1	(-)
J1 Terminal Block pos.7 (CHG)	Current Loop Chassis Ground	

Table 4-11 AMC-RAC to BAS Channel 2 Connection.

AMC-RAC	Function	BAS CH.2
J1 Terminal Block pos.18 (+)	CH2. Current Loop Positive 1	(+)
J1 Terminal Block pos.19 (-)	CH2. Current Loop Negative 1	(-)
J1 Terminal Block pos.20 (CHG)	Current Loop Chassis Ground	



Figure 4-12; below shows the wire length allowable between the AMC-1AREF monitor, AMC-RAM-4 and Building Automation System with different Load resistances recommended for the setups.

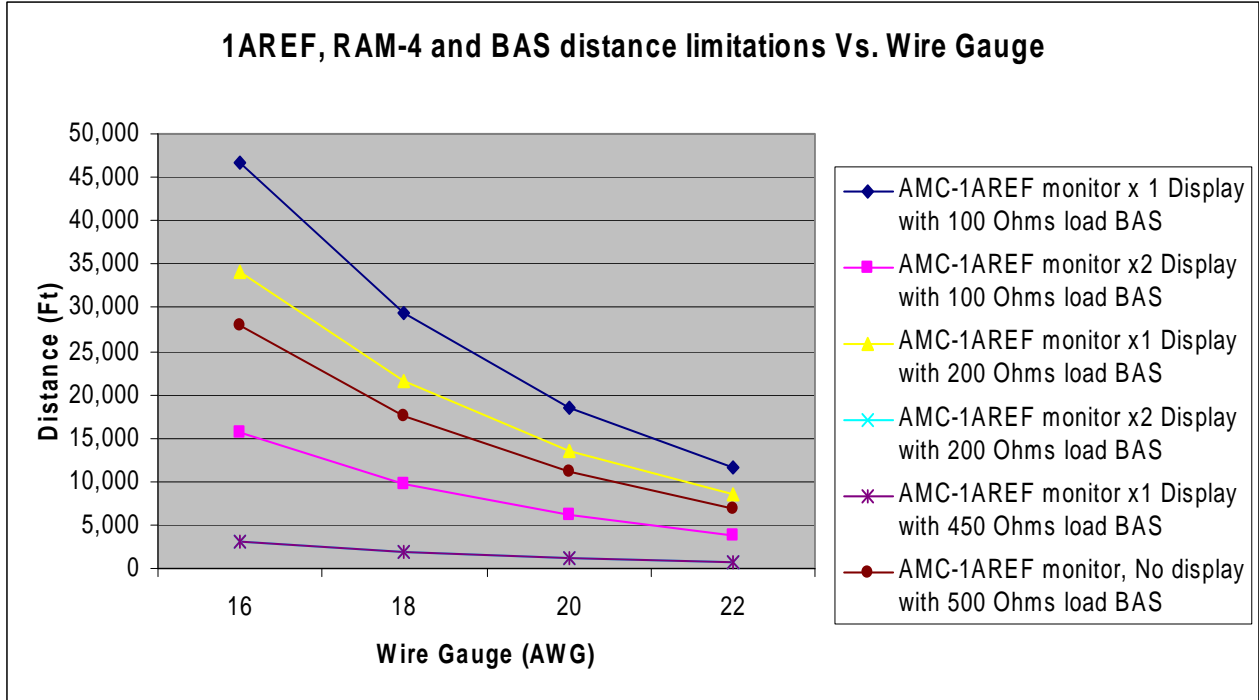

Figure 4-12 Graph showing distance (ft) vs. wire gauge (AWG) for various system setups.

Note:

1. Wire length for the following setups is the same; Gas Monitor 1A x2 Display with BAS 200 Ohms resistance and Gas Monitor 1A x 1Display with BAS 450 Ohms resistance.
2. Recommended maximum load resistance BAS is 200 Ohms per channel; for setup AMC-1AREF monitor, Ram-4 with 2 displays per channel

4.3 DIP SWITCH PROGRAMMING

The AMC-1AREF monitor circuit board has two blocks of DIP-switches for configuring the various functions; see Figure 2, item 13, carefully remove DSI board to access the DIP switches, no hot swapping. Each DIP-switch can be set to OFF (left position) or ON (right position) depending on functions required.

Table 4-12 DIP-Switch Programming Chart

Switch	Feature	Position	Description															
SW1-1	Activate Alarms until Acknowledge (Latching Relays)	OFF	Warning and alarm relays are automatically de-activated once activating condition has been removed and minimum run timer has expired.															
		ON	Once activated, warning and alarm relays remain activated (latched) until activation condition has been removed, minimum run timer has expired and the Acknowledge button has been pressed.															
SW1-2, SW2-2	Minimum Run Timer	See Description	Warning and alarm relays are maintained in alarm state for a minimum time interval following alarm activation, as follows: <table border="0" style="width: 100%; border-collapse: collapse;"> <tr> <td style="padding-right: 20px;">SW1-2</td> <td style="padding-right: 20px;">SW2-2</td> <td>Minimum Run Time</td> </tr> <tr> <td>OFF</td> <td>OFF</td> <td>0 minutes</td> </tr> <tr> <td>ON</td> <td>OFF</td> <td>5 minutes</td> </tr> <tr> <td>OFF</td> <td>ON</td> <td>10 minutes</td> </tr> <tr> <td>ON</td> <td>ON</td> <td>30 minutes</td> </tr> </table> Note that a sensor level falling below the alarm threshold and then re-occurring during this time resets the alarm timer for the associated alarm.	SW1-2	SW2-2	Minimum Run Time	OFF	OFF	0 minutes	ON	OFF	5 minutes	OFF	ON	10 minutes	ON	ON	30 minutes
SW1-2	SW2-2	Minimum Run Time																
OFF	OFF	0 minutes																
ON	OFF	5 minutes																
OFF	ON	10 minutes																
ON	ON	30 minutes																
SW1-3, SW1-4	Sensor Type (Mode Select)	See Description	Sensor type (threshold mode) is selected as follows: <table border="0" style="width: 100%; border-collapse: collapse;"> <tr> <td style="padding-right: 20px;">SW1-3</td> <td style="padding-right: 20px;">SW1-4</td> <td>Sensor Type (Mode)</td> </tr> <tr> <td>OFF</td> <td>OFF</td> <td>Both channels Increasing</td> </tr> <tr> <td>ON</td> <td>OFF</td> <td>Both channels Decreasing</td> </tr> <tr> <td>OFF</td> <td>ON</td> <td>Channel 1 Decreasing Channel 2 Increasing</td> </tr> <tr> <td>ON</td> <td>ON</td> <td>Reserved</td> </tr> </table>	SW1-3	SW1-4	Sensor Type (Mode)	OFF	OFF	Both channels Increasing	ON	OFF	Both channels Decreasing	OFF	ON	Channel 1 Decreasing Channel 2 Increasing	ON	ON	Reserved
SW1-3	SW1-4	Sensor Type (Mode)																
OFF	OFF	Both channels Increasing																
ON	OFF	Both channels Decreasing																
OFF	ON	Channel 1 Decreasing Channel 2 Increasing																
ON	ON	Reserved																
SW1-6	Number of Sensors	OFF	Channel 1 and 2 are enabled.															
		ON	Only channel 1 enabled.															



AMC-1AREF Series Refrigerant Monitor

Switch	Feature	Position	Description
SW1-7	Two Zone Enabled		Factory Configured
SW1-8	Enable One group of Relays		Factory Configured
SW2-1	Alarm Relay Activated when Fault is Detected	OFF	The Alarm relay is not activated when fault is detected.
		ON	When fault is detected, the Alarm relay is activated. <ul style="list-style-type: none">▪ When only one group of relays is selected (see SW1-8), if fail is detected on a channel which is enabled (see SW1-6) then the Alarm relay is activated▪ When two groups of relays are selected (see SW1-8), if fail is detected on a channel which is enabled (see SW1-6) then the Alarm relay associated with the channel is activated.
SW2-3	Audio Enable for Warning	OFF	Audio alarm is disabled for Warning conditions (2-threshold sensor modes only).
		ON	Audio alarm is activated in conjunction with Warning (2-threshold sensor modes only).
SW2-4	Sensor Fault Threshold	OFF	Sensor Fault thresholds set at 0.4 mA into 250R or 100 mV.
		ON	Sensor Fault thresholds set at 1.4 mA into 250R or 350mV.
SW2-5	Activation Delay, Warning or Sensor 1	OFF	No activation delay of Warning / S1 alarm conditions.
		ON	Five minute delay on activation of Warning (2-threshold) or Sensor 1 (1-threshold) alarm conditions following sensor exceeding alarm threshold.
SW2-6	Activation Delay, Alarm or Sensor 2	OFF	No activation delay of Alarm / S2 alarm conditions.
		ON	Delay on activation of Alarm (2-threshold) or Sensor 2 (1-threshold) alarm conditions following sensor exceeding alarm threshold.
SW2-7	Audio Alarm Enable	OFF	Audio alarm (buzzer) disabled.
		ON	Audio alarm (buzzer) enabled.

4.3.1 DSI INTERFACE CONFIGURATION

With the signal input configuration as shown in Table 10, the AMC-1AREF board is correctly configured for the DSI board. The DSI board will support 2 wire and 3 wire remote sensor/ Transmitters with a 4-20mA signal input for each channel. This input interface is configured by dip switches SW1 –SW5 for channel 1 and channel 2 as shown in Figure 4-13

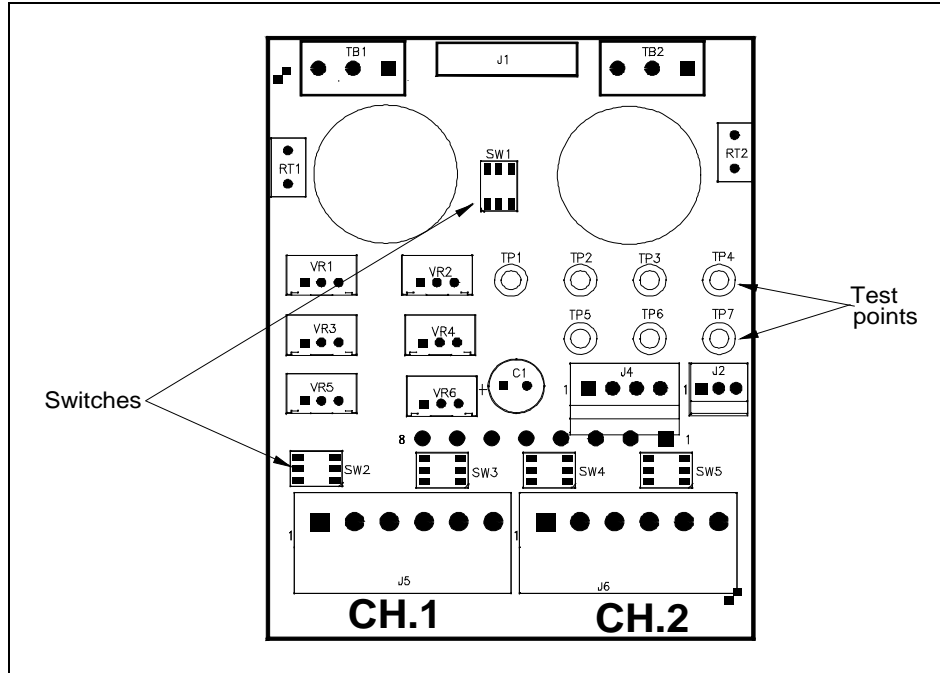

Figure 4-13 Detailed DSI Board.

A detailed description of each signal input configuration is in the following sub-sections: On-Board Sensor Connection, Transmitter and Building Automation wiring.

Table 4-13 Dip Switch setting for DSI board

Switch	Title	Position
SW1-1 Upper	Channel 2 Service Mode	Left –CH 2 Service Right- CH 2 Normal
SW1-2 Lower	Channel 1 Service Mode	Left – CH 1 Service Right –CH 1 Normal
SW3-1 Left	CH 2 Selector External or On Board Electro-chemical Sensor	Up – On Board Sensor Down – External
SW3-2 Right	CH 2 Selector External Input Resistor 10K or 100R	Up – 100R Input Resistor Down – 10K Input Resistor
SW4-1 Left	CH 1 Selector External or On Board Electro-chemical Sensor	Up – On Board Sensor Down – External
SW4-2 Right	CH 1 Selector External Input Resistor 10K or 100R	Up – 100R Input Resistor Down – 10K Input Resistor
SW5-1 Left	CH 2 Input Selector for Voltage or current	Up – CH2 Input Voltage Down – CH2 Input Current
SW5-2 Right	CH 1 Input Selector for Voltage or current	Up – CH1 Input Current Down – CH 1 Input Voltage



AMC-1AREF Series Refrigerant Monitor

Table 4-14 DSI board Test points (use a voltmeter with greater than 100K input resistance)

TP #	Title	Usage
1	VFD	Provides a voltage representation of the VFD output Measure between GND (TP4) and VFD (TP1) Range: Minimum 0 or 2V based upon SW2-2 No target (0 ppm) gas measured Range: Maximum 10V High gas concentration measured
2	S1	Provides a voltage representation of the gas concentration reported on channel 1 Measure between GND (TP4) and S1 (TP2) Range: Minimum 0V No target (0 ppm) gas measured, 0 mA on 4-20 mA input Range: Maximum 2V High gas concentration measured, 20 ma on 4-20 mA input
3	S2	Provides a voltage representation of the gas concentration reported on channel 2 Measure between GND (TP4) and S3 (TP3) Range: Minimum 0V No target (0 ppm) gas measured, 0 mA on 4-20 mA input Range: Maximum 2V High gas concentration measured, 20 ma on 4-20 mA input
4	GND	Reference ground, used with VFD (TP1), S1 (TP2) and S2 (TP3)
5	EC1	Provides a voltage representation of the gas concentration measured by on-board sensor channel 1 Measure between VREF (TP7) and EC1 (TP5) Range: Minimum 0V No target (0 ppm) gas measured Range: Maximum 1.6V Full SPAN / High gas concentration measured
6	EC2	Provides a voltage representation of the gas concentration measured by on-board sensor channel 2 Measure between VREF (TP7) and EC2 (TP6) Range: Minimum 0V No target (0 ppm) gas measured Range: Maximum 1.6V Full SPAN / High gas concentration measured
7	VREF	Virtual Ground reference, used with EC1 (TP5) and EC2 (TP6) Voltage between GND (TP4) and VREF (TP7): 2.5VDC



4.4 ALARM RELAY PROGRAMMING

The WARNING and ALARM relays may be configured as normally energized or normally de-energized with the jumper straps identified in Table 4-14 (WARNING and ALARM Relay Active State) and shown in Figure 3-2 item 9. Unless otherwise specified the “normally de-energized” position is employed, activating the relay when an alarm condition is detected. The “normally energized” position is selected when failsafe operation is required. For example, the requirement is that when power to the Gas Monitor is lost, the load connects to a power source via contacts of this, normally energized relay.

Table 4-15 WARNING and ALARM Relay Active State

Relay	Jumper	Normally De-Energized	Normally Energized
Warning	JB11	1-2	2-3
Alarm	JB12	1-2	2-3

NOTE:

The Ventilation Relay has a fixed function and is NOT programmable; only the WARNING and ALARM relays can be programmed. Please consult factory for grouping options or any other configurations.

4.5 AUDIO ALARMS

An audio alarm output is provided, which produces various alarm sounds, as shown in the table 13 below. The audio alarm can be disabled by turning OFF the DIP-switch SW2-7.

Table 4-16 Audio Alarm Operation

Sensor Status	Output
Normal	off
Warning (SW2-3 OFF, 2-threshold modes only)	off
Warning (SW2-3 ON, 2-threshold modes only)	two long, slow beeps. followed by short pause
Any Sensor (1-threshold modes), or Alarm (2-threshold modes)	four fast beeps, followed by short pause
Any Sensor Fault (with no unacknowledged alarms on opposite sensor)	short, slow beeps
Notes: 1) Micro-controller operation ensures that Warning, Alarm and Fault conditions will not occur simultaneously on the same sensor. 2) An Alarm or Warning condition on either sensor overrides a Fault condition on the opposite sensor.	



5 OPERATION AND CALIBRATION

This section covers the operation and calibration procedures pertaining to the AMC-1AREF series refrigerant monitor.

5.1 POWER-ON DELAY

Upon initial power up, and successful completion of all self-tests detection of sensor WARNING, ALARM and FAULT conditions is disabled for 30 seconds. This delay is provided to allow the sensors to stabilize. During this delay, the status LEDs shows the “sensor normal” condition (only the green LED on). The audio alarm is silent, and the alarm relay outputs are held in the non-alarm condition.

5.2 TEST SWITCH FUNCTION

While pressed, the on-board momentary test switch will simulate a full scale gas signal on all channels, causing continuous activation of the alarm relay outputs (energized or de-energized, depending on configuration), audio alarm (if enabled), and all status LEDs will be illuminated. Sensor signal processing and updating of internal status and timers continues unaffected by test mode. When the test switch is released the outputs and LEDs will return to normal operation.

5.3 AUDIO ACKNOWLEDGE FUNCTION

The AMC-1AREF series does not have an audio Acknowledge pushbutton switch option on the monitor. The audio alarm is acknowledged through the attached AMC-RAM-4 units inside the mechanical room. The RAM-4 units located inside the mechanical room have a FAN STOP push button which, when pressed will silence the audio alarm for 30 minutes. If the alarm condition persists after 30 minutes, the audio alarm will again be activated. The clearing of an alarm condition, and subsequent reactivation due to the presence of gas will cause an immediate audio alarm.

5.4 ALARM/WARNING RELAY ACTIVATION DELAYS

The Gas Monitor 1AREF series monitor comes standard with 5 min activation time delays for the WARNING and ALARM relay contacts. The activation time delays can help prevent short cycling WARNING/ALARM in some applications. The delays can be enabled by turning ON switches SW2-5 and SW2-6, for WARNING/ALARM respectively.



5.5 RELAY OUTPUTS

The AMC-1AREF is factory configured so that a WARNING condition on either sensor will result in activation of the WARNING relay output. An ALARM condition on either sensor will result in activation of both the WARNING and ALARM relay outputs.

Each programmable relay (WARNING, ALARM) may be selected as energized when active, or de-energized when active using on-board jumpers JB11 and B12, respectively. This option is provided to allow configuration flexibility. If configured to energize the relay when activated (jumpers set to “normally de-energized”), a controller failure or controller power failure will prevent an alarm condition from being produced. The opposite setting of jumpers (relay “normally energized”) will result in an alarm condition produced on reaching the gas threshold level, controller failure or controller power failure.

The AMC-1AREF has a third separate relay which controls ventilation, this relay is energized when the start button on the AMC-RAM-4 is pressed or when the warning threshold is exceeded; this starts the system ventilation and is de-energised when the stop button is pushed in or when gases alarms are cleared. The relay remains in the latched state for the as long as the alarm condition exists, thus the ventilation can not be stopped by pushing the stop button on the AMC-RAM-4, when alarms are still active shut down does not activate ventilation relay

5.6 GAS CONCENTRATION DISPLAY

The optional digital displays on the Gas Monitor 1AREF series monitor show the current gas concentration on Ch.1 or Ch.2. The display is completely user configurable and is designed to be able to work with the most common gas concentration ranges. For proper setup, refer to section 5.7.3 GAS CONCENTRATION DISPLAY SETUP.

5.7 CALIBRATION AND VERIFICATION

Calibration of the remote sensors/ transmitters is recommended two times per year and the correct operation of all peripherals and/or relays should be checked at the same time. For more demanding applications more frequent verification should be considered.

Please refer to the sensor/transmitter manual for calibration instructions.

The AMC-1AREF series system is factory calibrated prior to shipment. Periodic verification is required to validate trip points. For calibration assistance or direct service inquiries please contact the factory at (800)465-5777 or service@armstrongmonitoring.com.

5.7.1 TRIP THRESHOLD ADJUSTMENT

This section discusses the adjustment of the WARNING and ALARM thresholds on the Gas Monitor when connected to a 2 or 3-wire transmitter and DSI.

These transmitters and DSI supply a linear 4 to 20 mA signal to the monitor. This translates to a 0.4 to 2.0 volt DC signal at TP4 (Sensor 1) and TP1 (Sensor 2) see Figure 5-1. The alarms are set to correspond to some fraction of the transmitters full scale calibration, see section 2 PRODUCT INFORMATION.

Table 5-1 and Figure 5-1 below are provided to identify key components used in trip threshold adjustment.

- RV5 (sensor 1) and RV2 (sensor 2) are used to set a threshold at which the WARNING is triggered. TP5 (sensor 1) and TP2 (sensor 2) are used to monitor these WARNING levels.
- RV6 (sensor 1) and RV3 (sensor 2) are used to set a threshold at which the ALARM is triggered. TP6 (sensor 1) and TP3 (sensor 2) are used to monitor these ALARM levels.

Table 5-1 Test Points and Trimpots Allocation

Reference Points	Sensor/Channel 1	Sensor/Channel 2
Signal	TP4	TP1
WARNING	TP5	TP2
ALARM	TP6	TP3
Ground	TP22 (or TP3 on DSI board)	
WARNING	RV5	RV2
ALARM	RV6	RV3

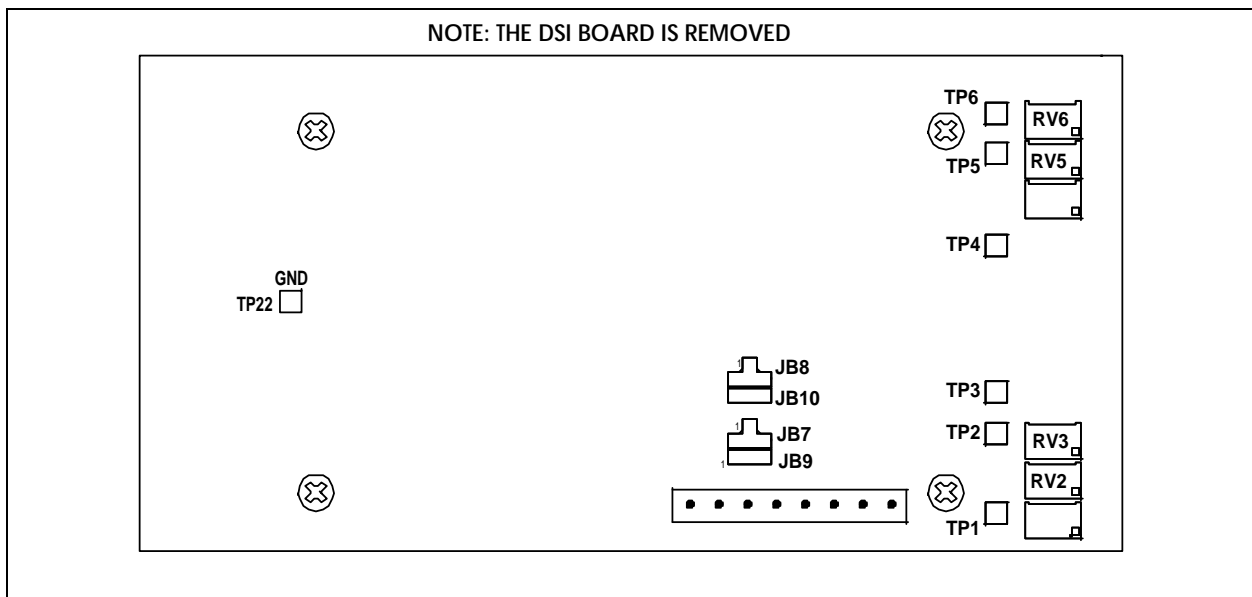

Figure 5-1 Gas Monitor 1AREF Test Points and Trimpots.



5.7.1.1 Equipment Required

- Digital multimeter with a minimum display range of 0 to 10.0 VDC.
- Miniature screwdriver trimmer adjustment tool.

5.7.1.2 Trip Threshold Adjustment

Ensure that the interface is configured for 4-20 mA transmitters. Both the table and formula below are used to determine the voltage the thresholds are adjusted to with the trimpots.

Table 5-2 Trip Threshold Adjustment

Alarm Level (VDC)	Span (ppm)						
	10	25	50	100	200	300	500
0.4	0	0	0	0	0	0	0
0.8	2.5	6.25	12.5	25	50	75	125
1.2	5.0	12.5	25	50	100	150	250
1.6	7.5	18.75	37.5	75	150	225	375
2.0	10	25	50	100	200	300	500

$$V_{\text{alarm}} = ((C_{\text{alarm}} / C_{\text{full scale}} * I_{\text{Range}}) + I_{\text{base}}) * R_{\text{termination}} * K_{\text{Gas Monitor 1A}}$$

Where

- V_{alarm} – The voltage measured at the alarm test point while adjusting the alarm trimpot.
- C_{alarm} - The target gas concentration for the alarm
- $C_{\text{full scale}}$ - The gas concentration corresponding to full scale (20 mA)
- I_{Range} – Calibrated at transmitter, typically 16 mA for full range.
 - $I_{\text{Range}} + I_{\text{base}}$ typically add to 20 mA.
- I_{base} – fixed at 4.0 mA
- $R_{\text{termination}}$ – fixed internally on Gas Monitor at 250 ohms
- $K_{\text{Gas Monitor 1A}}$ – constant which describes the scaling used within the Gas Monitor, fixed at 0.4

EXAMPLE 1: To set an ALARM threshold of 1000 PPM for a 4-20 mA transmitter calibrated for 20 mA for a concentration of 1000 PPM;

- C_{alarm} : 1000 PPM
- $C_{\text{full scale}}$: 1000 PPM
- I_{Range} : 20 mA – 4 mA = 16 mA
- $V_{\text{alarm}} = (((1000 \text{ PPM} / 1000 \text{ PPM}) * 16 \text{ mA}) + 4 \text{ mA}) * 250 * 0.4 = 2.0\text{V}$
- RV6 would be adjusted so that 2.0V is measured at TP6.

EXAMPLE 2: Using the same transmitter as example 1 set a WARNING threshold of 400 PPM;

- C_{alarm} : 400 PPM
- $C_{\text{full scale}}$: 1000 PPM
- I_{Range} : 20 mA – 4 mA = 16 mA
- $V_{\text{alarm}} = (((400 \text{ PPM} / 1000 \text{ PPM}) * 16 \text{ mA}) + 4 \text{ mA}) * 250 * 0.4 = 1.04\text{V}$



- RV5 would be adjusted so that 1.04V is measured at TP5.

5.7.2 2-WIRE AND 3-WIRE TRANSMITTERS

The calibration procedure of the two or three wire transmitters is specified in the corresponding transmitter manual.

5.7.3 GAS CONCENTRATION DISPLAY SETUP

There are two optional gas concentration displays; looking from the front of the enclosure, channel 1 is left and channel 2 display is right. The following setup is common for both displays.

The display needs to be configured to the required gas range. On the back side of the display, there are 8 DIP-switches (Figure 5-2). The first 4 switches control the range and 6, 7 and 8 controls the placement of the decimal point (switch 5 is not used). In Table 16 below, common gas ranges are listed with the corresponding DIP-switch selection. For decimal point placement, only one of the switches (6, 7 and 8) can be ON at once. The selected gas range must be calibrated to display accurate values by adjusting the Zero and Span trimmers (Figure 5-2). A test transmitter with 4-20 mA output is required to simulate zero and full scale outputs. Follow the steps below for proper setup.

1. Refer to Table 5-4 to select the desired gas range, change DIP-switch accordingly.
2. Set Zero and Span trimmers fully clockwise, refer to Figure 5-2.
3. Connect the test transmitter to the Gas Monitor 1AREF DSI board to respective channels (see Figure 4-8 and 4-9 for wiring samples).
4. Adjust transmitter to output 4.0 mA and adjust the display Zero trimmer so the display reads 0.
5. Adjust transmitter to output 20.0 mA and adjust the display Span trimmer so the display reads the selected full scale.
6. Repeat steps 4 and 5 to make sure the adjustments do not affect one another.
7. Remove the transmitter and reconnect the field wiring.

Note:

The above procedure is performed at the factory and should only be done when changing scales or if the display values have drifted.



Table 5-3 Display DIP-Switch Settings

<i>Range ppm</i>	<i>1</i>	<i>2</i>	<i>3</i>	<i>4</i>	<i>Decimal Point</i>
1.000	ON	OFF	OFF	OFF	6
3.00	OFF	OFF	ON	OFF	7
10.00	ON	OFF	OFF	OFF	7
25.0 (% for O ₂)	OFF	ON	ON	OFF	8
50.0	OFF	ON	OFF	OFF	8
100.0	ON	OFF	OFF	OFF	8
200	OFF	ON	ON	OFF	None
300	OFF	OFF	ON	OFF	None
400	OFF	ON	OFF	OFF	None
500	OFF	ON	OFF	OFF	None
1000	ON	OFF	OFF	OFF	None

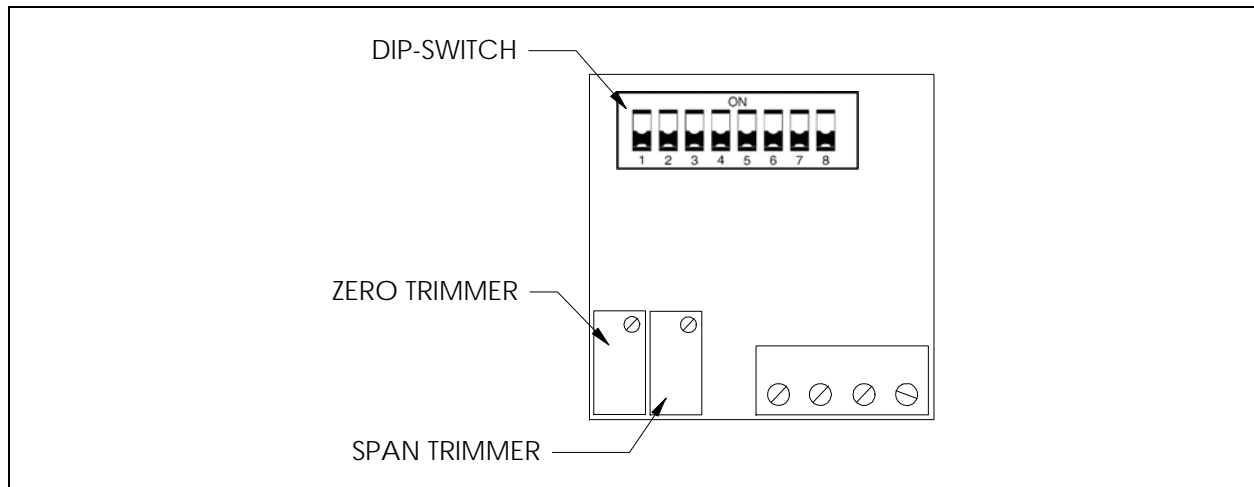

Figure 5-2 Back View of Gas Concentration Display



6 PREVENTIVE MAINTENANCE

This section covers all aspects of the Gas Monitor 1AREF series monitor. First, a description of general maintenance is given followed by a verification of operation and sensor replacements.

6.1 GENERAL

The monitor unit should be brushed or wiped clean, once a year or more, of any dust or dirt that settles on it, depending on the accumulation.

The unit SHOULD NOT be submerged in water or other liquids. Also, spraying and/or other conditions that could cause a liquid to enter the enclosure must be avoided.

6.2 VERIFICATION OF OPERATION

Verification of operation should be performed at least once every 6 months. For highly demanding applications more frequent verification is recommended.

6.3 SENSOR REPLACEMENT

The sensor should be replaced when the sensor no longer adequately responds to test gas. Refer to the corresponding manuals for the respective transmitter which outline the sensor replacement procedure.

CAUTION

TURN OFF THE MAIN POWER SUPPLY BEFORE ATTEMPTING THE SENSOR REPLACEMENT.



7 INSTALLATION TIPS AND TRICKS

CABLING

- Cabling – use 2 conductor cable with 2 wire transmitter and 3 conductor cable for 3 wire transmitters. Generally, 18 gauge conductors are used (not true in all cases). Shielded twisted wires must be used to connect all gas sensors.
- Route cabling in conduit to avoid damage to cabling.
- Sensor cable shield must be grounded at the monitor end only; the cable shield at the sensor must be clipped short and wrapped with electrical tape to avoid electrical contact with any components in the housing.
- Route cabling away from AC power cabling and any source of electro-magnetic interference (EMI) or radio frequency interference (RFI) such as power transformers, electric motors, etc.
- All cabling must enter the sensors and monitors from the bottom to ensure protection against water damage due to water inside the conduit from condensation or leaks if the conduit entry was elsewhere.
- Ensure that there are no short or open circuits in the sensor cabling.
- Verify that there is no AC or DC voltage or shorts present on the sensor cabling prior to connecting the cabling to either the sensor or the monitor.

EQUIPMENT LOCATION

- Mount all equipment away from any source of electro-magnetic interference (EMI) or radio frequency interference (RFI) such as power transformers, electric motors, etc.
- Mount sensors in accordance with the installation guidelines for the specific species of gas to be detected; i.e. CO sensors should be mounted at breathing height etc.
- Equipment must be positioned such that the chance of water or physical damage is minimized; i.e. away from fire suppression sprinkler heads, away from wet or damp locations where there would be a risk of water damage.
- Ensure a balanced layout of sensors to cover the intended area.
- Ensure that sensors are not in close proximity to clean air sources.

POWER AND GROUNDING

- All power and grounding connections to equipment must be made in accordance with applicable electrical and building codes.
- Use a separate, dedicated, noise free, 15 amp power circuit, with an appropriately labeled circuit breaker.